

TOP TIPS FOR ENCOURAGING READING AT HOME

Create a Reading Routine

Set aside a specific time each day for reading. Consistency helps make reading a habit.



Make Reading Fun

Choose engaging and fun books that match your child's interests.

Lead by Example

Show that you value reading by reading yourself. Children mimic parent behaviors.

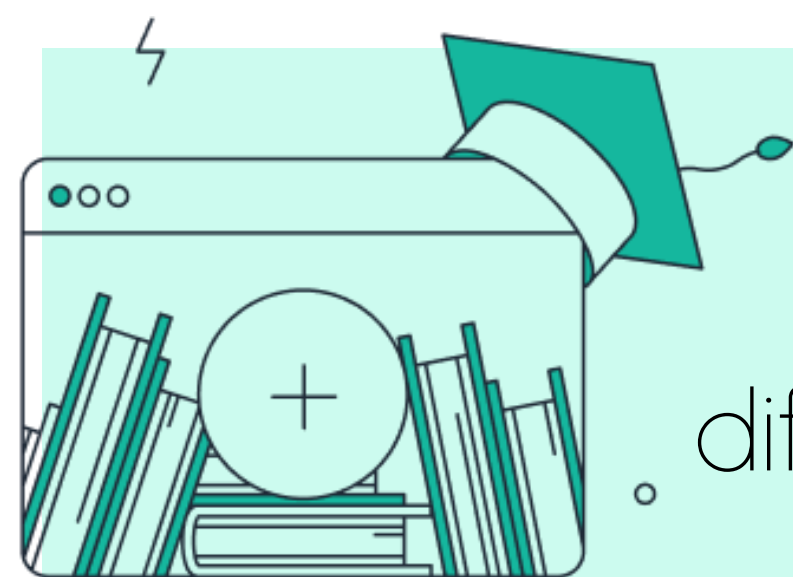

Build a Home Library

Have a variety of books available at home. Include different genres and topics to keep their interest up..

Discuss Books Together

Ask questions about the story, plot and characters and their thoughts on the book.

Visit Libraries and Bookstores

Regular visits to libraries and bookstores can make book selection an exciting event.

Use Technology

Use tools like Bookmarked that offer curriculum-based questions for parents to ask, ensuring comprehension and engagement with the material.



Connect Books to Real Life

Relate stories to real-life experiences. It helps children understand what they read.

Praise and Encourage

Always praise their reading efforts and progress to build confidence.